

**TRAILER HITCH FOR HARLEY- DAVIDSON FLHTCUTG
TRI GLIDES 2011 & Newer - Including Freewheeler
#HD007-TG113
INSTALLATION INSTRUCTIONS**

1. Remove the hitch and hardware from the box and familiarize yourself with the components. Lay out the trailer hitch under the rear of the Trike so the flanges with the bolt holes are facing up. Notice there are eight holes in the frame's cross members that align with the holes in the hitch. It will be bolted on using the four outermost holes.
2. On the rear cross member locate the two T40 Torx head screws next to the mufflers mounting brackets. Remove these screws using a T40 tamperproof wrench being careful not to strip the heads. These screws are installed with thread locking compound at the factory. It will help greatly to heat the heads of the screws to about 200 degrees using a propane torch. This will break down the thread-locking compound and they will loosen much easier.
3. Locate the supplied $\frac{1}{4}$ " x $\frac{3}{4}$ " x 14" "nut bar". Notice that the holes in the nut bar are offset to one side and that the holes in the front cross member are as well. Slide the nut bar into the "U" shape of the cross member so that the holes in the nut bar will align with those in the cross member when installed. Locate the four supplied 5/16"-18 x 1 $\frac{1}{4}$ " bolts, washers and lock washers. Place a drop of thread locker (Loc-Tite) onto the threads of each bolt. Holding the hitch up in place and aligning with the holes in the cross member start two of the bolts with lock and flat washers in the rear holes. Next start the two remaining bolts with lock and flat washers in the front holes while aligning the threaded holes of the nut bar. Tighten all four bolts securely (15-18 ft. lbs.)
4. Slide the tongue into the receiver and install the supplied pin with clip. Note the Bolt on the side of the hitch can be tightened to eliminate any movement or rattle between the tongue and receiver.
5. Wiring: (not supplied with hitch) Refer to the instructions supplied with wiring sub-harness, isolator and 5 to 4 wire convertor.

NOTE: we offer a sub-harness (plug and play), which provides a plug in connection from motorcycle to the isolator, 5 to 4 wire convertor and trailer plug.

NOTE: If your trailer uses more than two (2) incandescent tail light bulbs the use of a trailer wiring isolator is strongly advised as this additional load is too much for the motorcycle's wiring to support, and may cause damage to the electrical system. Trailer wiring isolators are available thru RIVCO Products (or at some auto parts stores). If you are installing both you must first install the 5 to 4 wire converter, then the isolator, then attach to the trailer plug.

NOTE: If your trailer has only four (4) wires you will need to use a 5 to 4 wire converter. These are available thru RIVCO Products (or at most auto parts stores).

HD007TG11
INSTALLATION

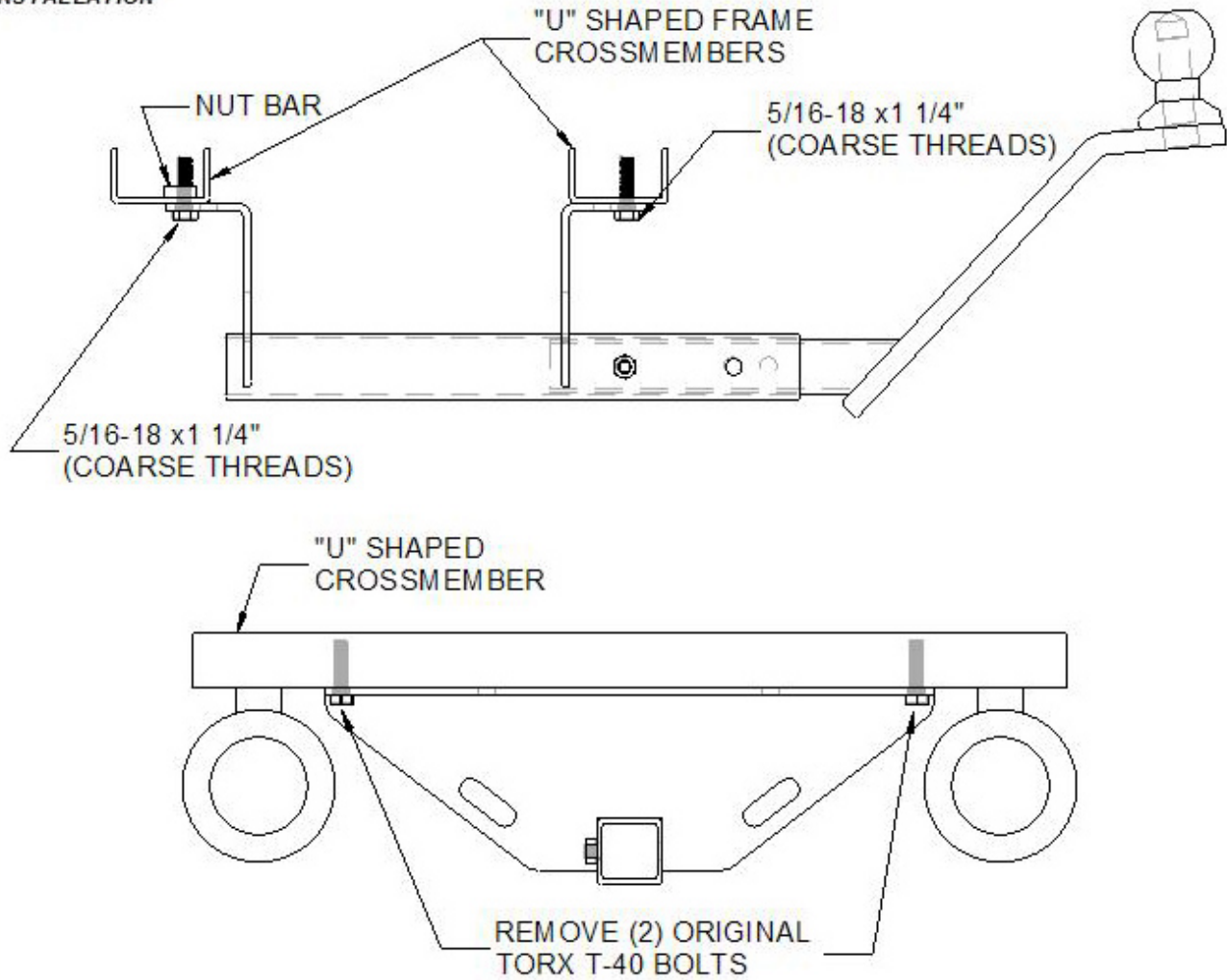

TRAILER TOWING GUIDELINES AND SAFETY

Remember that this is only a guide and should be supplemented with your own common sense for safe operation.

WARNING: TOWING A TRAILER BEHIND A MOTORCYCLE OR TRIKE IS DONE SO AT YOUR OWN RISK AND INCREASES THE LIKELIHOOD OF INJURY OR DEATH TO BOTH OPERATOR AND PASSENGER DUE TO INCREASED RISK AND EXPOSURE. FAILURE TO OBSERVE THE FOLLOWING WILL FURTHER INCREASE THE RISK OF INJURY OR DEATH TO OPERATOR AND PASSENGER.

- (A) ALL HIGHWAY SAFETY WARNINGS, RULES AND LAWS,
- (B) MAINTENANCE AND OPERATION INSTRUCTIONS ASSOCIATED WITH THIS HITCH OR YOUR TRAILER,
- (C) POSTED SPEED AND ROAD CONDITION WARNINGS,
- (D) SAFE RIDING PRACTICES AND PROCEDURES

We are aware of no current state or federal guidelines for pulling a trailer with a Motorcycle or Trike. We suggest when pulling and loading a trailer that you do not exceed the Manufacturer's Gross Vehicle Weight and tongue weight limits.

When pulling a trailer extra distance must be allowed for stopping.

When cornering, use slower speeds and a wider angle of attack.

Use extra caution at all times, particularly if the road surface is wet or slippery.

Splitting lanes with a trailer is HIGHLY discouraged and is ILLEGAL in many states.

IMPORTANT: AS A SAFETY PRECAUTION CHECK THE FOLLOWING BEFORE EVERY TRIP:

*Visual Inspection Of Hitch And Mounting Bolts. *Safety Chains Are Attached Properly.

*Trailer Lights Function Properly. *Hitch Pin On & Clipped. *Check Air Pressure In Trailer Tires.

Thank you for purchasing a RIVCO Product!



440 South Pine Street
Burlington, WI 53105
262-763-8222
rivcoproducts.com

To register your product's warranty and view hundreds of other bagger and cruiser accessories, please visit our website.